

Bu Resim MESA OTO ELEKTRİK LTD.ŞTİ'nin malıdır. Şirket Yetkililerinin izni olmaksızın kopya edilemez, üzerinde değişiklik yapılamaz.
This image MESA AUTO ELECTRIC LTD.'s are property. Can not be copied without the consent of the company authorized, any changes can be made.

PARÇA KODU PART CODE	PARÇA ADI PART NAME	ERKEK TERMINAL MALE TERMINAL	a ÖLÇÜSÜ (AYAR) a MEASURE (SET)	s ÖLÇÜSÜ (KALINLIK) s MEASURE (THICKNESS)	Malzeme Material	Kaplama / Coating		
						SN	AG	Nİ
TD 2156.50 RP	YASSI D.F.TEK NOKTALI (ORTA NOKTA) B.A.2.8 (0.50)=RP=	0.50	0.40±0.05	-----	(CuZn30) Pirinç / Brass	-	-	-
TD 2156.50 RPK	YASSI D.F.TEK NOKTALI (ORTA NOKTA) B.A.2.8 (0.50)=RPK=	0.50	0.40±0.05	-----	(CuZn30) Pirinç / Brass	+	-	-
TD 2156.80 RP	YASSI D.F.TEK NOKTALI (ORTA NOKTA) B.A.2.8 (0.80)=RP=	0.80	0.70±0.05	-----	(CuZn30) Pirinç / Brass	-	-	-
TD 2156.80 RPK	YASSI D.F.TEK NOKTALI (ORTA NOKTA) B.A.2.8 (0.80)=RPK=	0.80	0.70±0.05	-----	(CuZn30) Pirinç / Brass	+	-	-

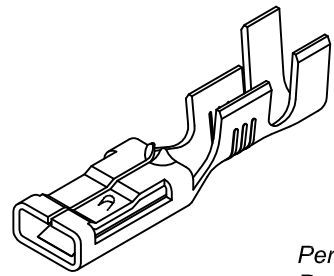
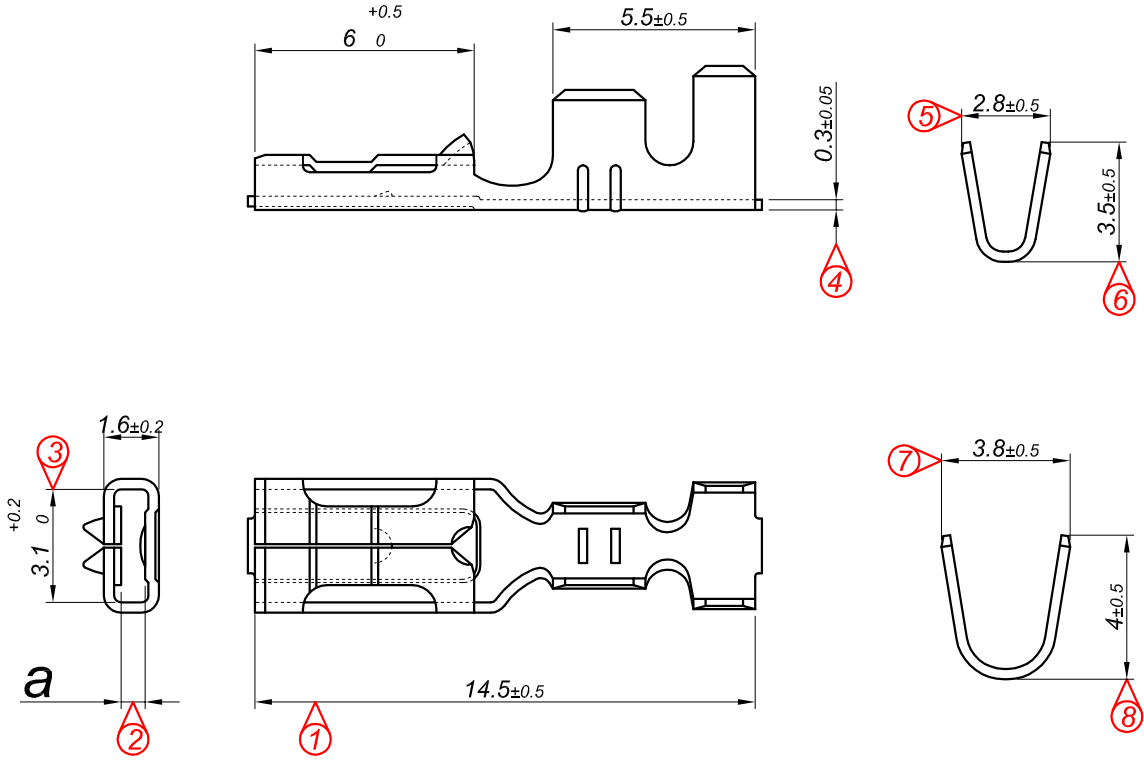

Perspektif
Perspective

Kalıp çıkış yönü
Mold output direction ← → Makara açılım yönü
Reel opening direction

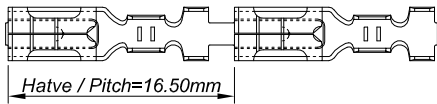

Hatve / Pitch=16.50mm

Ölçek
Scale : 2 / 1

Kablo Kesiti
Wire Section : 0.5 - 1.50 mm²

Resim üzerinden ölçü almayınız
do not measure on drawing

Tarih / Date	20.03.2013	İmza /Signature	Ölçek /Scale			
Çizen / Desing	M.Yağcı					
Onay / Approval	S.Gölcük		5 / 1	No	Değişiklik / Revision	Tarih/Date
	Parça Adı: Part Name	YASSI DİŞİ FİŞ TEK NOKTALI (ORTA NOKTA) BÜYÜK AYAK 2.8			Parça Kodu: Part Code	TD 2156